

ROBOTTI

We automate farming



Specialized for repetitive precision work

ROBOTTI LR

We automate farming



A **GROINTELLI** is a Danish field robotics company, founded in 2015. Initially, working closely together with universities and research institutions, the company introduced various innovative precision agricultural technologies that received many innovation awards.

We offer ROBOTTI through our growing network of approved distributors internationally and through direct sales in Denmark. In this way, you enjoy the best customer support and local knowledge of how to integrate ROBOTTI into your farming business. In addition, our in-house sales support and product teams are always here to assist your transition into robotic farming.

"Background"



ROBOTTI is more than just a robot being able to treat of the field – it is the digital infrastructure enabling automatic data collection in the field, crop as well as technical data, that can support decision support and management systems. ROBOTTI is multi-purpose, which means it can do different types of field operations. It is a tool carrier, designed to embrace a large variety of well-known and well-proven implements. It is suited perfectly for precision plant nursing like seeding, weeding, ridging and spraying. The design of ROBOTTI also makes use of standard and well-understood components, making it robust and easily serviceable.

ROBOTTI is already in operation at farms throughout Europe and around the world. With ROBOTTI, you can robotize certain processes in your field and achieve significant benefits by doing so.

The new ROBOTTI LR is designed for long working hours, with low power consumption, and up to 60 hours before refueling. It has a high on-wheel torque, improved hydraulics and a lifting capacity of 1.2 tons. It is a cost-effective machine which is easy to integrate into your present-day practices in your fields, at horticulture sites, and nurseries or similar sites with crops in rows or bed systems.

What is **unique** about ROBOTTI?

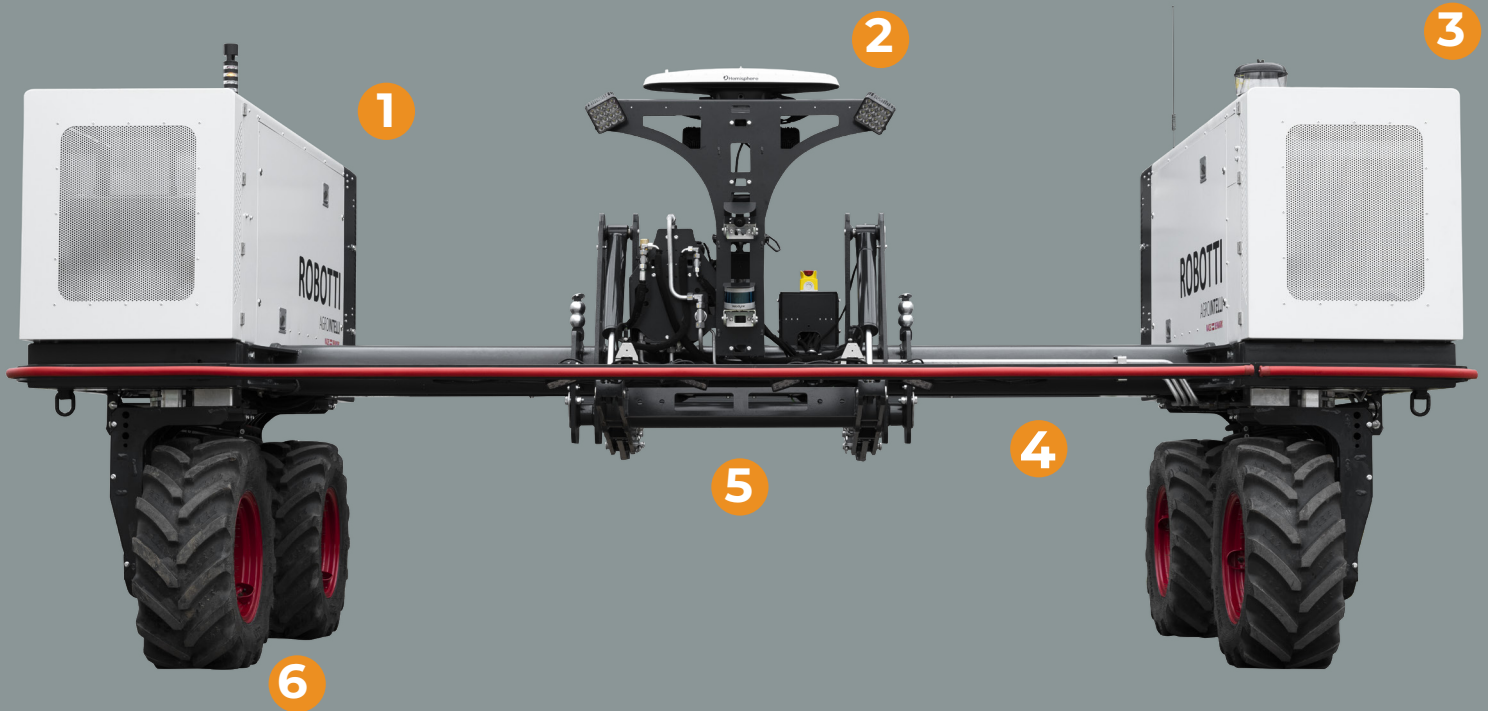

1 "Set and go"

ROBOTTI can perform field operations for you - without a driver. It can operate day and night - 24/7.

2 Precise operation for tighter margins

ROBOTTI's dual RTK-GPS positioning system gives +/- 2 cm accuracy in the field. ROBOTTI drives exactly the same place every time.

3 An engine your mechanics already know

With Kubota diesel engine, ROBOTTI's horsepower is never in doubt. Engine maintenance is simple and parts are widely available.

4 Safe by design with several safety systems

ROBOTTI has multiple redundant safety systems. You can leave ROBOTTI to work with total confidence and it will notify you when it has completed the job.

5 Easy linkage and power transfer

ROBOTTI LR has a standard 3-point hitch, category 2. This means universal compatibility and easy customization to standard implements.

6 Light footprint, healthy soil

Weighing around 3.000 kg, ROBOTTI is a lightweight well-balanced alternative to conventional tractors. Designed to eliminate the risk of sub-soil compaction.

A replacement for labor shortages

Farmers are currently facing a lack of skilled labor and strict environmental restrictions all over the world. This calls for new ways of working and even more important – new ways of thinking.

ROBOTTI LR is one of the possible tools to overcome these challenges. It will work up to 60 hours and carry out precise work with the same quality hour after hour, day after day. And it is a sustainable solution enabling the reduction of chemical use in farming and has a low consumption of energy due to its low weight. This reduces the risk of soil compaction from driving in the fields compared with heavy conventional machines.

Advanced yet simple

ROBOTTI is an ideal mix of state-of-the-art intelligent electronics with a simple mechanical machine - traditional diesel-hydraulic drivetrain and a 3-point hitch.

The power comes from a Stage V Kubota engine and the hydraulic propulsion system comes from Bosch Rexroth. Therefore, ROBOTTI is very reliable.



Zero-Turn

ROBOTTI can spin around a stationary point with a zero turning radius. The unique steering system enables ROBOTTI to turn on narrow headlands and, in this way, increase the utilization of the field. This increases the yields in e.g., bed systems, where headlands are not usually farmed.



We carry your tools

In the middle of the center-boom, a standard 3-point hitch is installed. This allows the robot to work with different implements throughout the season.

The working width between the modules can be customized from 1.5 to 3.3 meters depending on the individual needs. The typical tasks of ROBOTTI are seeding, weeding, ridging, and spraying.

"Robotizing - seeding and plant nursing"

Safety first

Safety was given uncompromising attention throughout the development of ROBOTTI. It is CE marked and complies with the EU Directives and all relevant ISO standards.

The safety system of ROBOTTI is based on 7 different safety systems from simple physical systems to virtual fencing. If one of them is ever triggered, ROBOTTI stops and notifies you.

- 3D laser scanner (LIDAR)
- Pressure sensitive bumper
- GPS-based virtual fencing
- Off track monitoring, with wheel slip surveillance and getting stuck avoidance system
- Stop button on the remote controller
- Stop function via the mobile interface or via the web-based surveillance system
- 5 emergency stop buttons

When planning the operation and creating a field plan, you mark all known obstacles, such as fences, power poles, bushes, etc. In all other cases, no worries, ROBOTTI reacts quickly, stopping immediately if obstructed by people or animals.

Working with ROBOTTI is like working with a conventional irrigation machine – bring it to the field, push the start button, check up on it now and then – and fetch it when the job is done.



"Smart repetitive work"



ROBOTTI is not only hardware

Automated farming with field plan software

ROBOTTI is controlled by a computer in real time and does not need a human driver. Based on your inputs, it calculates and navigates following an optimized route in the field. ROBOTTI navigates precisely with RTK-GPS technology - an accuracy of +/- 2 cm. With ROBOTTI's website, you can plan, supervise the robot live, view in real time when the job will be finished, and document the work on the go. It is user friendly, easy to plan the work and start the field operation. Just go pick it up when you receive the sms!

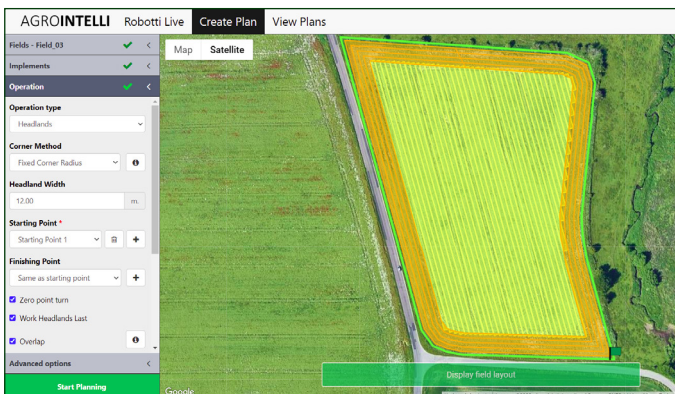

Step 1

Create your plan

Add your implement's specifications, choose or upload the borders of your field and determine how the operation is to be carried out. Accept the plan and see the expected time of operation.

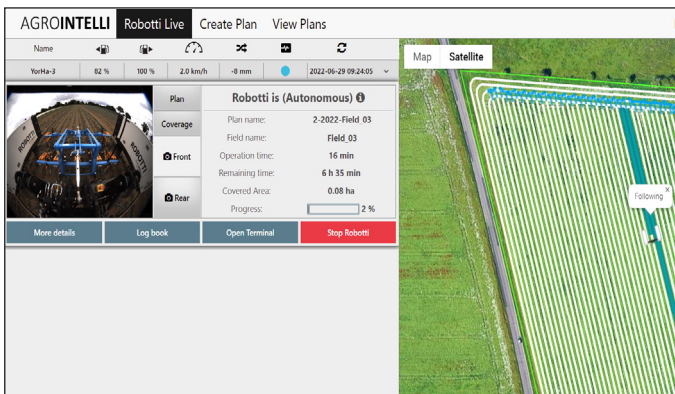

Step 2

Monitor the progress

Follow the progress of the operation, monitor the performance of the machine and check the front and rear surveillance cameras.

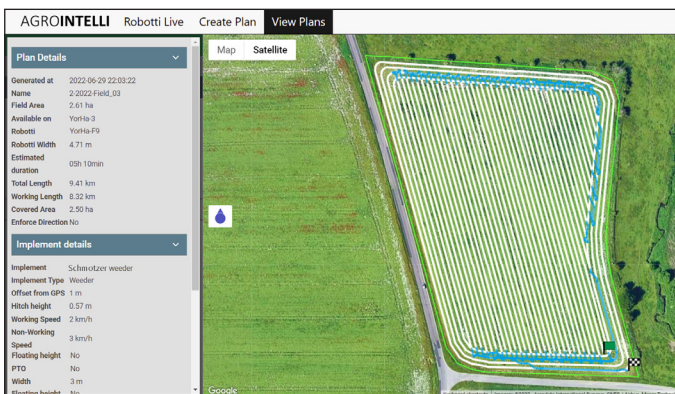

Step 3

Documentation

Each of your operations are documented with information about the original plan, the operational time, as well as a visual display of the area covered or accuracy of the driving. An overview of your plans and operations for each of your fields can be viewed on the website too.

"Let **ROBOTTI** do your work for you"

Choose your working width

Front view

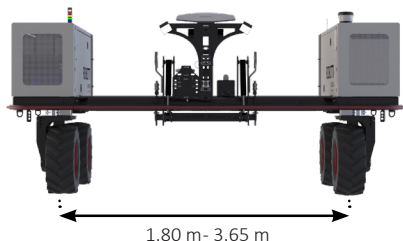

Top view

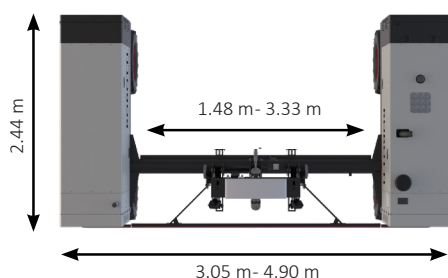

Side view

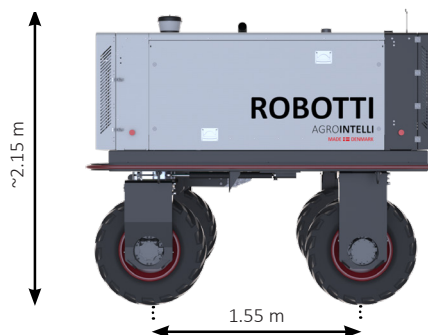

Note: Other measurements available on request

Technical specifications

ROBOTTI Model	LR
ENGINE	
Manufacturer	Kubota, diesel
Number of engines	1
Cylinders per engine	4
Total engine gross power	54/72 (kW/hp)
Battery voltage	12V
Environmental standard	EPA/CARB Tier4 + EU Stage V
Diesel tank	300 l
TRANSMISSION SYSTEM	
Forward speed in automated mode	Up to 5 km/h (3.1 mph)
Forward speed in manual mode	Up to 10 km/h (6.2 mph)
HYDRAULIC SYSTEM	
Hydraulics	Bosch Rexroth Load-Sensing
Hydraulic connectors	3 double acting outlets (max. 50 l/min) + free return
SAFETY AND NAVIGATION	
Pressure sensitive bumper and emergency stop buttons	Standard
GNSS-based virtual fencing	Standard
Remote controller/joystick	Standard
LIDAR laser scanner	Standard
RTK-GNSS (GPS)	Standard
Vision computer and camera package (front and rear)	Optional
Light package (front and rear)	Optional
ADDITIONAL SPECIFICATIONS	
Lift capacity of the tree-point hitch	1250 kg
Dry weight	2850 kg
Drive system	4-wheel drive
Steering	2-wheel steering / Zero-Turn



Wide (Default)
BKT Agrimax 320-65 R16
Width: 31.9 cm



Narrow
BKT Agrimax 260-70 R16
Width: 25.8 cm

AGROINTELLI

Please do not hesitate to contact us for further information.

Dealer:

Agro Intelligence ApS
Agro Food Park 13,
8200 Aarhus N, Denmark

+45 93 63 30 01
contact_us@agrointelli.com
www.agrointelli.com